

Angular Contact Ball Bearings

1. Structure and Characteristics

1.1 Single row angular contact ball bearings / duplex angular contact ball bearings

A line connecting the contact points of both the ball and inner ring and ball and outer ring forms an angle to a line drawn radially: that angle is called the contact angle.

An angular contact ball bearing, while designed for radial loads, can accommodate single direction axial loads. Under radial loads and the resulting axial force component, the bearings are generally used in a duplex arrangement. More information on types and characteristics of duplexed angular

contact ball bearings is shown in **Table 1**.

Cage types and special features of single and multi-row angular contact ball bearings are shown in **Fig.1**. **Drawings A** through **F** feature the inner ring guide cage. **Drawings B** and **C** illustrate cages with lubrication ports. **Drawings D** and **E** feature a rolling element guide cage; **E** also shows the cage with a lubrication port. Note that the inner ring width in **drawing F** is larger than that of the outer ring.

Table 1 Duplex angular contact ball bearings

Arrangement type		Characteristics	
Back-to-back duplex arrangement (Code: DB)		These bearings support the radial loads and both direction of axial loads.	<ul style="list-style-type: none"> • Since the distance "l" between the cone pressure apexes of bearing is large, the load capacity of the moment load is high. • Permissible slant angle is small.
Face-to-face duplex arrangement (Code: DF)			<ul style="list-style-type: none"> • The distance "l" between the cone pressure apexes of bearing is small in comparison with the back-to-back duplex arrangement, the load capacity of the moment load is low. • Permissible slant angle is larger than the back-to-back duplex arrangement type.

Notes: 1. Since the bearings are manufactured in a set to adjust for the internal clearance or pre-loading, **parts with same serial number must be used for assembly.**

2. Combination of more than 3 bearings may occur. Please consult NTN Engineering for details.

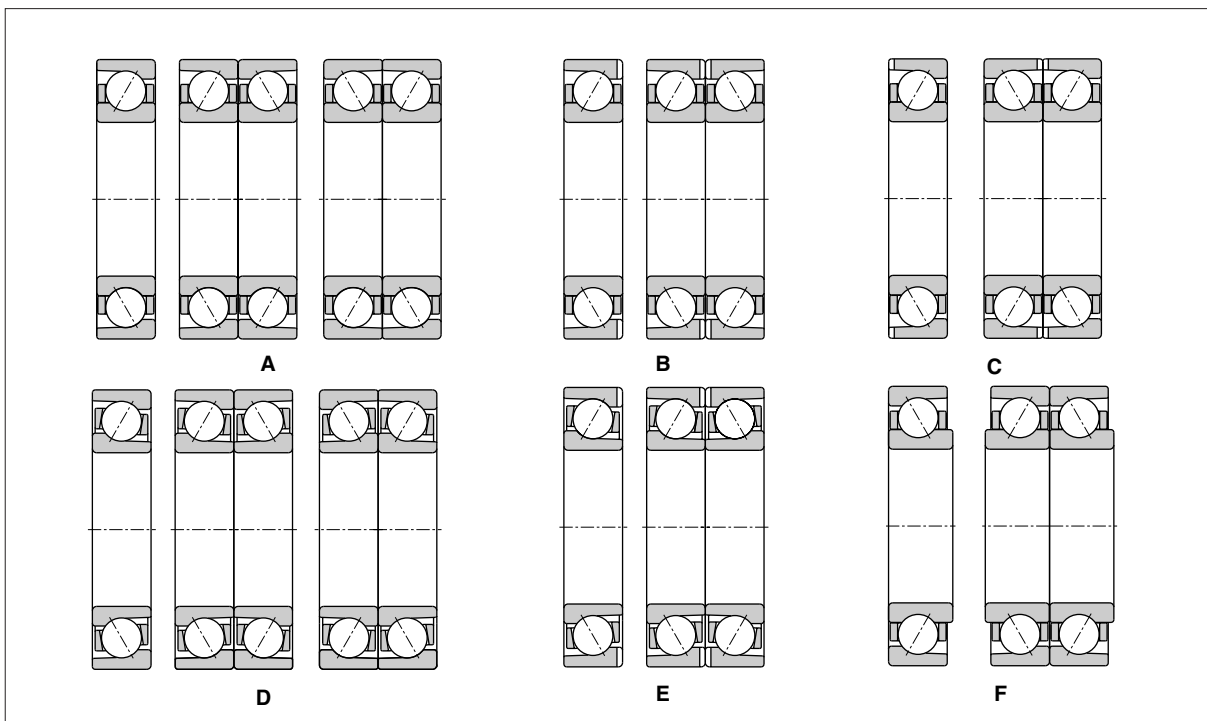

Fig.1 Single row/duplex angular contact ball bearings

1.2 Double row angular contact ball bearings

Two single row angular contact ball bearings when duplexed back-to-back (DB) so that the inner ring forms one piece are used to create double row angular contact ball bearings. Alternatively, the bearings may be duplexed face-to-face (DF) with the outer ring as one piece.

These bearings support radial and axial loads in either direction: back-to-back duplexed bearings also support moment loads.

The cage type and special shape of the double row angular contact ball bearings are shown in **Fig.2** with the list of drawing numbers in the dimensions table.

The **drawings A** and **B** are the front-to-front duplex arrangement; drawing 2 is a bearing with a lubricating port; **drawings** from **C** to **G** show the back-to-back duplex arrangement and the different position of the lubricating ports whether or not there are lubricating grooves. **Drawing C** shows the inner ring width larger than that of outer ring.

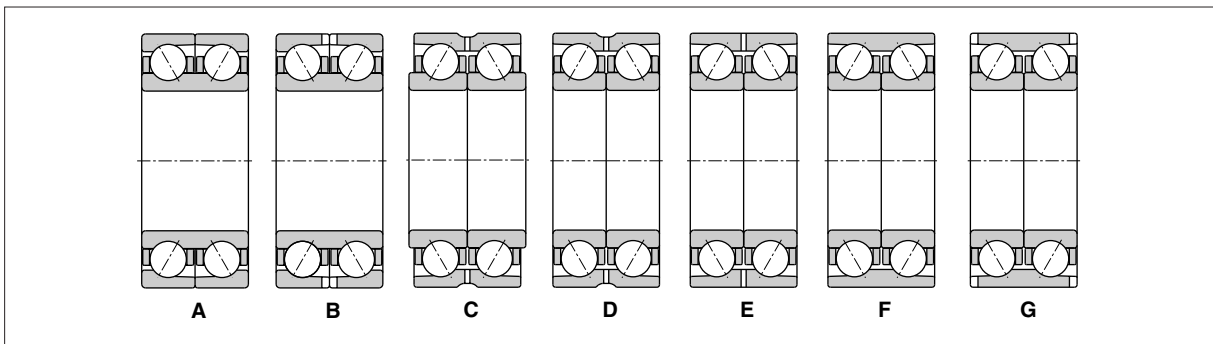

Fig.2 Double row angular contact ball bearings drawing

2. Dimensional Accuracy/Rotation Accuracy

Refer to Table 3.3 (Page A-12)

Single row/Duplex angular contact ball bearings
Double row angular contact ball bearings

3. Recommended Fitting

Refer to Table 4.2 (Page A-24)

Single row/Duplex angular contact ball bearings
Double row angular contact ball bearings

4. Bearing Internal Clearance

Refer to Table 5.3 (Page A-31)

Duplex angular contact ball bearings
Double row angular contact ball bearings

5. Cautions for Operation

When the bearing loads are small (about $F_r \leq 0.02C_{or}$) or the ratio between the axial and radial loads of the duplex bearing exceeds the value "e", slippage may occur between the balls and the raceways. This slippage may cause smearing. Particularly with large size angular contact ball bearings, this tendency is significant since the ball and cage mass is large. Please consult with NTN Engineering for further details.



Angular Contact Ball Bearings (Single, Duplex)

NTN

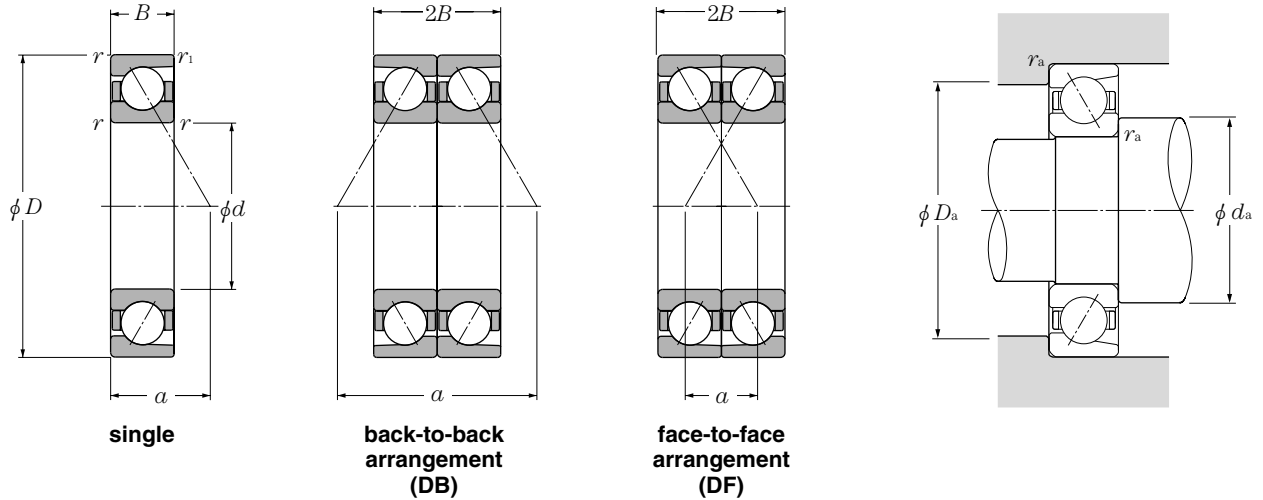

d 100~130mm

d	Boundary dimensions					contact angle α	dynamic C_r	Basic load ratings			Bearing numbers single	Drawing ^① No.	Load center a	Mass single kg (approx.)	
	mm							kN	static C_{or}	single					
	D	B	C	$r_{s\ min}^{②}$	$r_{is\ min}^{②}$					dynamic C_r					static C_{or}
100	125	13	—	1	0.6	30	21.2	25.2	2,160	2,570	7820	A	39	0.36	
	140	20	—	1.1	0.6	30	48.0	52.5	4,900	5,350	7920	A	44.5	0.93	
	150	24	—	1.5	1	30	68.5	70.5	6,950	7,200	7020	A	48	1.47	
	150	24	—	1.5	1	40	61.0	63.5	6,250	6,500	7020B	A	64.5	1.49	
	180	34	—	2.1	1.1	30	144	126	14,700	12,800	7220	A	57.5	3.2	
	180	34	—	2.1	1.1	40	130	114	13,300	11,700	7220B	A	76	3.26	
	215	47	—	3	1.1	30	207	193	21,100	19,700	7320	A	69	7.18	
	215	47	—	3	1.1	40	190	178	19,400	18,100	7320B	A	89.5	7.32	
105	130	13	—	1	0.6	30	21.7	26.5	2,210	2,700	7821	A	40.5	0.37	
	145	20	—	1.1	0.6	30	48.5	54.5	4,950	5,550	7921	A	46	0.97	
	160	26	—	2	1	30	80.0	81.5	8,150	8,350	7021	A	51.5	1.86	
	160	26	—	2	1	40	71.5	73.5	7,300	7,500	7021B	A	68.6	1.88	
	190	36	—	2.1	1.1	30	157	142	16,000	14,400	7221	A	60.5	3.79	
	190	36	—	2.1	1.1	40	142	129	14,500	13,100	7221B	A	80	3.87	
	225	49	—	3	1.1	30	220	210	22,400	21,500	7321	A	72	8.2	
	225	49	—	3	1.1	40	202	194	20,600	19,700	7321B	A	93.5	8.36	
110	140	16	—	1	0.6	30	31.0	38.0	3,200	3,850	7822	A	44	0.58	
	150	20	—	1.1	0.6	30	49.5	56.0	5,050	5,700	7922	A	47.5	1.01	
	170	28	—	2	1	30	92.0	93.0	9,350	9,450	7022	A	54.5	2.3	
	170	28	—	2	1	40	82.5	83.5	8,400	8,550	7022B	A	72.8	2.34	
	200	38	—	2.1	1.1	30	170	158	17,300	16,100	7222	A	64	4.45	
	200	38	—	2.1	1.1	40	154	144	15,700	14,700	7222B	A	84	4.54	
	240	50	—	3	1.1	30	246	246	25,100	25,100	7322	A	76	9.6	
	240	50	—	3	1.1	40	226	226	23,000	23,100	7322B	A	99	9.8	
120	150	16	—	1	0.6	30	31.5	40.0	3,250	4,050	7824	A	47	0.63	
	165	22	—	1.1	0.6	30	61.0	69.5	6,200	7,100	7924	A	52	1.66	
	180	28	—	2	1	30	93.5	98.5	9,550	10,000	7024	A	57.5	2.47	
	180	28	—	2	1	40	84.0	89.0	8,550	9,050	7024B	A	77	2.51	
	215	40	—	2.1	1.1	40	165	162	16,900	16,500	7224B	A	90.5	6.26	
	215	40	—	2.1	1.1	30	183	177	18,600	18,100	7224	A	68.5	6.26	
	260	55	—	3	1.1	30	246	252	25,100	25,700	7324	A	82.5	14.7	
	260	55	—	3	1.1	40	225	231	23,000	23,600	7324B	A	107	14.7	
130	165	18	—	1.1	0.6	30	42.0	53.0	4,300	5,400	7826	A	51.5	0.91	
	180	24	—	1.5	1	30	75.0	87.5	7,650	8,900	7926	A	56.5	1.82	
	199.5	33	—	2.5	1	30	117	125	12,000	12,900	SF2652	A	64	3.74	

① Drawing details are shown in Page B-15.

② Smallest allowable dimension for chamfer dimension r or r_1 .

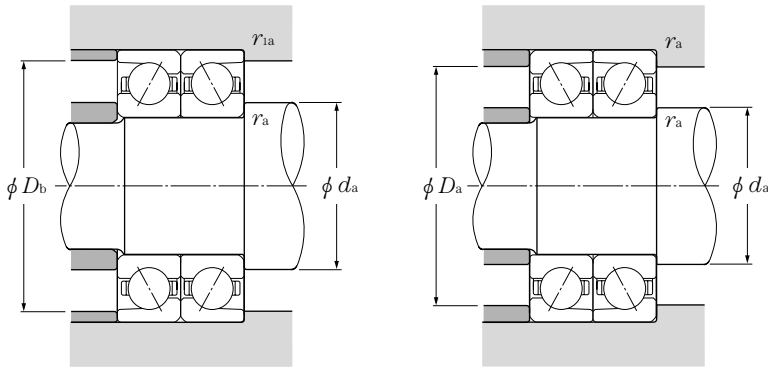

Equivalent bearing load

dynamic

$$P_r = XF_r + YF_a$$

Contact angle	e	Single				DB, DF			
		$F_a/F_r \leq e$		$F_a/F_r > e$		$F_a/F_r \leq e$		$F_a/F_r > e$	
		X	Y	X	Y	X	Y	X	Y
30°	0.80	1	0	0.39	0.76	1	0.78	0.63	1.24
40°	1.14	1	0	0.35	0.57	1	0.55	0.57	0.93

static

$$P_{or} = X_o F_r + Y_o F_a$$

Contact angle	Single		DB, DF	
	X _o	Y _o	X _o	Y _o
30°	0.5	0.33	1	0.66
40°	0.5	0.26	1	0.52

For single, When $P_{or} < F_r$ use $P_{or} = F_r$

dynamic	Basic load ratings		static	Bearing numbers		Load center		Abutment and fillet dimensions			
	static	dynamic (duplex)		DB	DF	DB	DF	mm			
	KN	kgf						d_a min	D_a max	r_{as} max	r_{ias} max
C_r	C_{or}	C_r	C_{or}	DB	DF	DB	DF	d_a min	D_a max	r_{as} max	r_{ias} max
34.0	50.5	3,500	5,150	DB	DF	78	52	105.5	119.5	1	0.6
78.0	105	7,950	10,700	DB	DF	109	69	107	133	1	0.6
111	141	11,300	14,400	DB	DF	120	72	108.5	141.5	1.5	1
76.5	127	10,100	13,000	DB	DF	129	81	108.5	141.5	1.5	1
233	251	23,800	25,600	DB	DF	149	81	112	168	2	1
212	229	21,600	23,300	DB	DF	186	118	112	168	2	1
335	385	34,500	39,500	DB	DF	185	91	114	201	2.5	1
310	355	31,500	36,000	DB	DF	226	132	114	201	2.5	1
35.0	53.0	3,600	5,400	DB	DF	81	55	110.5	124.5	1	0.6
79.0	109	8,050	11,100	DB	DF	112	72	112	138	1	0.6
130	163	13,300	16,700	DB	DF	129	77	115	150	2	1
116	147	11,900	15,000	DB	DF	137	85	115	150	2	1
254	283	25,900	28,900	DB	DF	157	85	117	178	2	1
231	258	23,500	26,300	DB	DF	196	124	117	178	2	1
355	420	36,500	43,000	DB	DF	193	95	119	211	2.5	1
330	385	33,500	39,500	DB	DF	236	138	119	211	2.5	1
50.5	76.0	5,150	7,750	DB	DF	88	56	115.5	134.5	1	0.6
80.0	112	8,150	11,400	DB	DF	115	75	117	143	1	0.6
149	186	15,200	18,900	DB	DF	137	81	120	160	2	1
134	167	13,600	17,100	DB	DF	145.5	89.5	120	160	2	1
276	315	28,100	32,500	DB	DF	166	90	122	188	2	1
250	289	25,500	29,400	DB	DF	206	130	122	188	2	1
400	490	41,000	50,000	DB	DF	202	102	124	226	2.5	1
365	455	37,500	46,000	DB	DF	248	148	124	226	2.5	1
51.5	79.5	5,250	8,100	DB	DF	94	62	125.5	144.5	1	0.6
99.0	139	10,100	14,200	DB	DF	126	82	127	158	1	0.6
152	197	15,500	20,100	DB	DF	143	87	130	170	2	1
136	178	13,900	18,100	DB	DF	154	98	130	170	2	1
269	325	27,400	33,000	DB	DF	221	141	132	203	2	1
297	355	30,500	36,000	DB	DF	177	97	132	203	2	1
400	505	41,000	51,500	DB	DF	220	110	134	246	2.5	1
365	460	37,500	47,000	DB	DF	269	159	134	246	2.5	1
68.5	106	6,950	10,800	DB	DF	103	67	137	158	1	0.6
121	175	12,400	17,800	DB	DF	137	89	138.5	171.5	1.5	1
191	251	19,400	25,600	DB	DF	128.5	62.5	142	187.5	2	1



Angular Contact Ball Bearings (Single, Duplex)

NTN

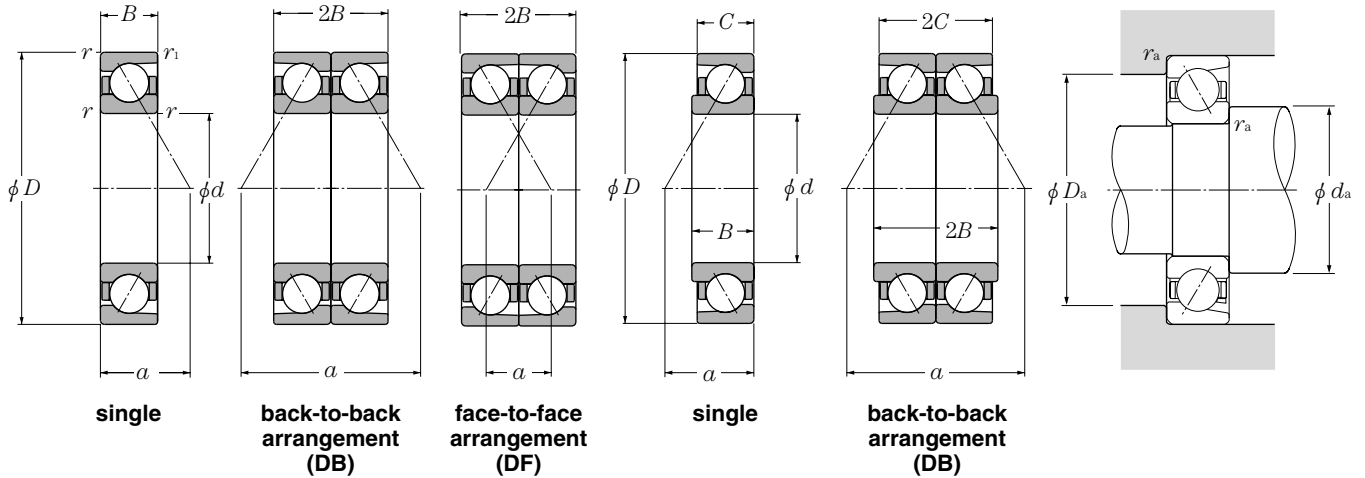

d 130~160mm

d	Boundary dimensions					contact angle α	dynamic C_r	Basic load ratings			Bearing numbers single	Drawing ^① No.	Load center a	Mass single (approx.)	
	mm							kN	single						kgf
	D	B	C	$r_{s\ min}^{\text{②}}$	$r_{is\ min}^{\text{②}}$				C_{or}	C_r					
130	200	33	—	2	1	30	117	125	12,000	12,800	7026	A	64	3.73	
	200	33	—	2	1	40	105	113	10,700	11,500	7026B	A	86	3.78	
	205	24	—	2.5	1	30	75.0	90.0	7,650	9,150	SF2608	A	60.5	2.98	
	230	40	—	3	1.1	30	196	198	20,000	20,200	7226	A	72	7.15	
	230	40	—	3	1.1	40	177	180	18,100	18,300	7226B	A	95.5	7.15	
	280	58	—	4	1.5	30	273	293	27,900	29,800	7326	A	88	17.6	
	280	58	—	4	1.5	40	250	268	25,500	27,400	7326B	A	115	17.6	
140	175	18	—	1.1	0.6	30	43.0	55.5	4,350	5,650	7828	A	54.5	0.97	
	190	24	—	1.5	1	30	75.5	90.0	7,700	9,150	7928	A	59.5	1.94	
	210	33	—	2	1	30	120	133	12,200	13,500	7028	A	67	3.96	
	210	33	—	2	1	40	107	119	10,900	12,100	7028B	A	90	4.01	
	250	42	—	3	1.1	30	203	215	20,700	21,900	7228	A	77.5	8.78	
	250	42	—	3	1.1	40	183	195	18,700	19,900	7228B	A	103	8.78	
	300	62	—	4	1.5	30	300	335	30,500	34,500	7328	A	94.5	21.5	
	300	62	—	4	1.5	40	275	310	28,100	31,500	7328B	A	123	21.5	
145	220	38	—	2.5	1.5	30	148	158	15,100	16,100	SF2951	A	71.7	5.15	
150	190	20	—	1.1	0.6	30	54.5	70.5	5,550	7,200	7830	A	59	1.35	
	210	28	—	2	1	30	97.5	117	9,900	11,900	7930	A	66	2.96	
	225	35	—	2.1	1.1	30	137	154	14,000	15,700	7030	A	71.5	4.82	
	225	35	—	2.1	1.1	40	122	138	12,500	14,000	7030B	A	96	4.88	
	270	45	—	3	1.1	30	232	259	23,700	26,400	7230	A	83	11	
	270	45	—	3	1.1	40	210	235	21,400	24,000	7230B	A	111	11	
	320	65	—	4	1.5	30	330	380	33,500	39,000	7330	A	100	25.1	
	320	65	—	4	1.5	40	300	350	30,500	36,000	7330B	A	131	25.1	
160	200	20	—	1.1	0.6	30	55.5	74.0	5,650	7,550	7832	A	62	1.42	
	215	28	25	2.5	1.1	40	75.5	93.0	7,700	9,450	SF3208	F	91	2.74	
	220	28	—	2	1	30	98.5	121	10,000	12,300	7932	A	69	3.13	
	229.5	33	—	2.5	1	40	111	128	11,300	13,100	SF3209	A	98.5	4.52	
	229.5	33	—	2.5	1	40	111	128	11,300	13,100	SF3214	C	98.5	4.52	
	230	33	—	2.5	1	30	124	147	12,600	15,000	SF3210	A	73	4.15	
	240	38	—	2.1	1.1	30	155	176	15,800	18,000	7032	A	77	5.96	
	240	38	—	2.1	1.1	40	139	158	14,100	16,100	7032B	A	103	5.98	
	290	48	—	3	1.1	30	263	305	26,800	31,500	7232	A	89	13.7	
	290	48	—	3	1.1	40	238	279	24,200	28,400	7232B	A	118	13.7	
	340	68	—	4	1.5	30	345	420	35,500	43,000	7332	A	106	29.8	

① Drawing details are shown in Page B-15.

② Smallest allowable dimension for chamfer dimension r or r_1 .

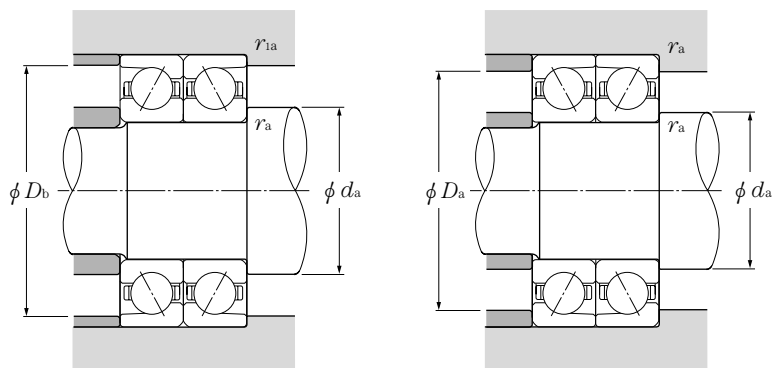

Equivalent bearing load

dynamic

$$P_r = X F_r + Y F_a$$

Contact angle	e	Single				DB, DF			
		$F_a/F_r \leq e$		$F_a/F_r > e$		$F_a/F_r \leq e$		$F_a/F_r > e$	
		X	Y	X	Y	X	Y	X	Y
30°	0.80	1	0	0.39	0.76	1	0.78	0.63	1.24
40°	1.14	1	0	0.35	0.57	1	0.55	0.57	0.93

static

$$P_{or} = X_o F_r + Y_o F_a$$

Contact angle	Single		DB, DF	
	X _o	Y _o	X _o	Y _o
30°	0.5	0.33	1	0.66
40°	0.5	0.26	1	0.52

For single, When $P_{or} < F_r$ use $P_{or} = F_r$

dynamic	Basic load ratings		static	Bearing numbers		Load center		Abutment and fillet dimensions			
	static	dynamic (duplex)		DB	DF	DB	DF	d_a min	D_a max	r_{as} max	r_{ias} max
C_r	KN	C_r	kgf								
191	251	19,400	25,600	DB	DF	161	95	140	190	2	1
171	226	17,400	23,100	DB	DF	171.5	105.5	140	190	2	1
122	180	12,500	18,300	DB	DF	120.5	72.5	142	193	2	1
320	395	32,500	40,500	DB	DF	184	104	144	216	2.5	1
288	360	29,400	36,500	DB	DF	231	151	144	216	2.5	1
445	585	45,500	59,500	DB	DF	234	118	148	262	3	1.5
405	535	41,500	54,500	DB	DF	288	172	148	262	3	1.5
69.5	111	7,100	11,300	DB	DF	109	73	147	168	1	0.6
123	180	12,500	18,300	DB	DF	143	95	148.5	181.5	1.5	1
194	265	19,800	27,000	DB	DF	167	101	150	200	2	1
174	237	17,700	24,200	DB	DF	180	114	150	200	2	1
330	430	33,500	44,000	DB	DF	197	113	154	236	2.5	1
297	390	30,500	40,000	DB	DF	248	164	154	236	2.5	1
490	670	50,000	68,500	DB	DF	251	127	158	282	3	1.5
445	615	45,500	63,000	DB	DF	308	184	158	282	3	1.5
241	315	24,500	32,000	DB	DF	143.5	67.5	157	208	2	1.5
88.5	141	9,000	14,400	DB	DF	118	78	157	183	1	0.6
158	234	16,100	23,900	DB	DF	160	104	160	200	2	1
222	305	22,700	31,500	DB	DF	178	108	162	213	2	1
199	275	20,300	28,100	DB	DF	192.5	122.5	162	213	2	1
375	515	38,500	53,000	DB	DF	211	121	164	256	2.5	1
340	470	34,500	48,000	DB	DF	267	177	164	256	2.5	1
535	765	54,500	78,000	DB	DF	265	135	168	302	3	1.5
490	700	50,000	71,500	DB	DF	327	197	168	302	3	1.5
90.5	148	9,200	15,100	DB	DF	124	84	167	193	1	0.6
123	186	12,500	18,900	DB	—	182.5	132.5	172	203	2	1
160	241	16,300	24,600	DB	DF	166	110	170	210	2	1
180	256	18,300	26,100	DB	DF	196.5	130.5	172	217.5	2	1
180	256	18,300	26,100	—	DF	196.5	130.5	172	217.5	2	1
201	293	20,500	29,900	DB	DF	145.5	79.5	172	218	2	1
252	355	25,700	36,000	DB	DF	192	116	172	228	2	1
225	315	23,000	32,500	DB	DF	206	130	172	228	2	1
425	615	43,500	62,500	DB	DF	226	130	174	276	2.5	1
385	555	39,500	57,000	DB	DF	284	188	174	276	2.5	1
565	845	57,500	86,000	DB	DF	280	144	178	322	3	1.5

Angular Contact Ball Bearings (Single, Duplex)

NTN

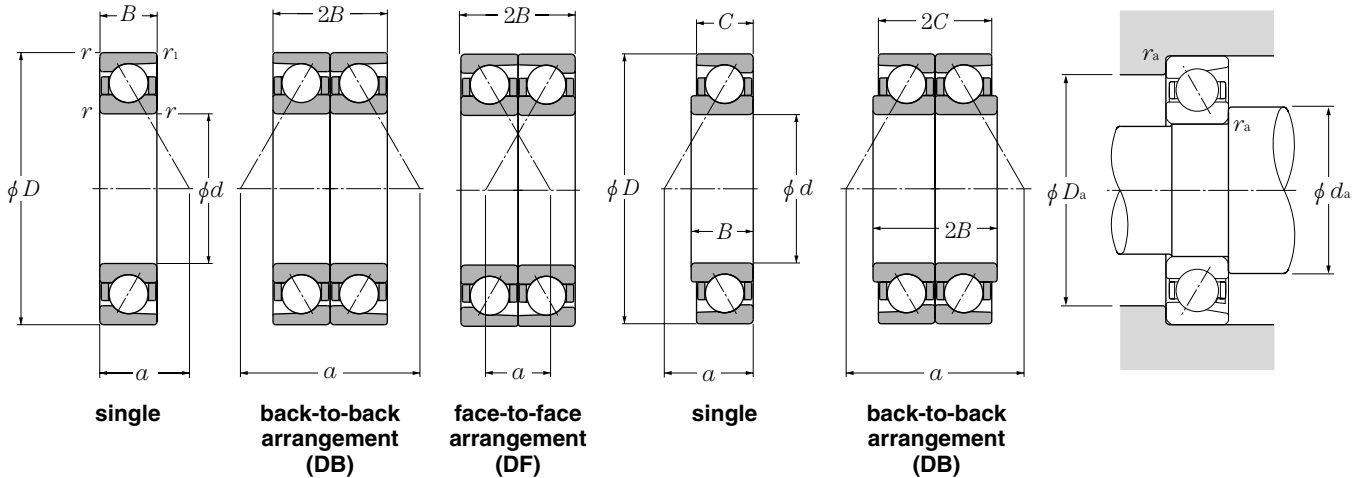

d 160~195mm

d	Boundary dimensions					contact angle α	dynamic C_r	Basic load ratings			Bearing numbers single	Drawing ^① No.	Load center mm a	Mass single kg (approx.)
	D	B	C	$r_{s\ min}^{\text{②}}$	$r_{is\ min}^{\text{②}}$			static kN C_{or}	dynamic single kgf C_r	static kgf C_{or}				
160	340	68	—	4	1.5	40	315	385	32,000	39,500	7332B	A	139	29.8
	215	22	—	1.1	0.6	30	68.5	90.5	6,950	9,250	7834	A	66.5	1.88
170	230	28	—	2	1	30	102	129	10,400	13,100	7934	A	71.5	3.29
	260	42	—	2.1	1.1	30	186	214	18,900	21,900	7034	A	83	7.96
	260	42	—	2.1	1.1	40	166	193	17,000	19,700	7034B	A	111.5	8.02
	310	52	—	4	1.5	30	295	360	30,000	36,500	7234	A	95.5	17
	310	52	—	4	1.5	40	266	325	27,200	33,000	7234B	A	127	17
	360	72	—	4	1.5	30	390	485	39,500	49,500	7334	A	113	35.3
	360	72	—	4	1.5	40	355	445	36,000	45,500	7334B	A	147	35.3
	180	225	22	—	1.1	0.6	30	70.0	95.0	7,100	9,700	7836	A	69.5
250		33	—	2	1	30	131	163	13,400	16,600	7936	A	78.5	4.87
259.5		33	—	2.5	1	40	138	166	14,100	16,900	SF3618	B	109	5.7
259.5		33	—	2.5	1	30	178	211	18,200	21,500	SF3629	C	80	5.8
259.5		33	—	2.5	1	30	178	211	18,200	21,500	SF3639	B	80	5.75
259.5		33	—	2.5	1	30	155	190	15,800	19,400	SF3641	C	80	5.65
280		46	—	2.1	1.1	30	219	266	22,300	27,100	7036	A	89.5	10.4
280		46	—	2.1	1.1	40	196	240	20,000	24,400	7036B	A	119.5	10.5
320		52	—	4	1.5	30	305	385	31,000	39,000	7236	A	98	17.7
320		52	—	4	1.5	40	276	350	28,100	35,500	7236B	A	131	17.7
380		75	—	4	1.5	30	410	535	41,500	54,500	7336	A	118	40.9
380	75	—	4	1.5	40	375	490	38,000	50,000	7336B	A	155	40.9	
190	240	24	—	1.5	1	30	85.0	116	8,650	11,800	7838	A	74	2.55
	255	33	29	2.5	1.5	40	108	138	11,000	14,100	SF3806	F	108	4.16
	259.5	33	—	2	1	30	133	169	13,500	17,200	SF3816	C	81.5	5.1
	260	33	—	2	1	30	133	169	13,500	17,200	7938	A	81.5	5.1
	269.5	33	—	2.5	1.5	30	132	168	13,500	17,100	SF3802	A	83	5.95
	269.5	33	—	2.5	2.5	40	134	166	13,600	16,900	SF3807	B	113	6.05
	290	46	—	2.1	1.1	30	224	280	22,800	28,600	7038	A	92.5	10.8
	290	46	—	2.1	1.1	40	201	253	20,400	25,800	7038B	A	124	10.9
	340	55	—	4	1.5	30	305	390	31,000	39,500	7238	A	104	21.3
	340	55	—	4	1.5	40	273	355	27,800	36,000	7238B	A	139	21.3
	400	78	—	5	2	30	430	585	44,000	59,500	7338	A	124	47
400	78	—	5	2	40	390	535	40,000	54,500	7338B	A	163	47	
195	270	35	—	2.5	1.5	30	153	196	15,600	20,000	SF3901	C	84.5	6.2

① Drawing details are shown in Page B-15.

② Smallest allowable dimension for chamfer dimension r or r_1 .

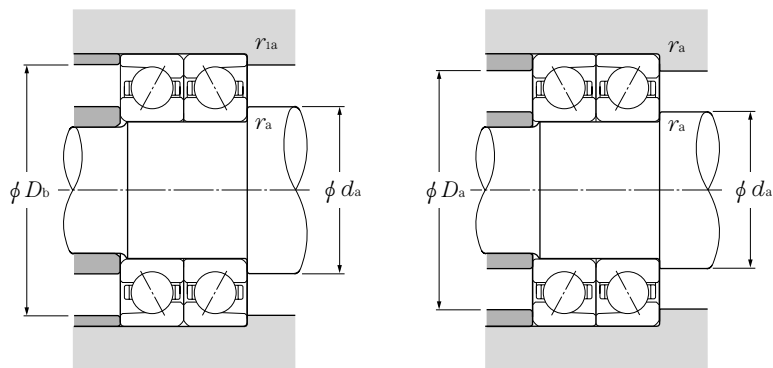

Equivalent bearing load

dynamic

$$P_r = X F_r + Y F_a$$

Contact angle	e	Single				DB, DF			
		$F_a/F_r \leq e$	$F_a/F_r > e$	X	Y	$F_a/F_r \leq e$	$F_a/F_r > e$	X	Y
30°	0.80	1	0	0.39	0.76	1	0.78	0.63	1.24
40°	1.14	1	0	0.35	0.57	1	0.55	0.57	0.93

static

$$P_{or} = X_o F_r + Y_o F_a$$

Contact angle	Single		DB, DF	
	X_o	Y_o	X_o	Y_o
30°	0.5	0.33	1	0.66
40°	0.5	0.26	1	0.52

For single, When $P_{or} < F_r$ use $P_{or} = F_r$

dynamic	Basic load ratings		static	Bearing numbers		Load center		Abutment and fillet dimensions				
	static	dynamic (duplex)		static	static	DB	DF	DB	DF	d_a min	D_a max	r_{as} max
C_r	KN	C_r	kgf	C_{or}	DB	DF	DB	DF				
515	770	52,500	79,000	DB	DF	346	210	178	322	3	1.5	
111	181	11,300	18,500	DB	DF	133	89	177	208	1	0.6	
165	257	16,900	26,200	DB	DF	171	115	180	220	2	1	
300	430	31,000	43,500	DB	DF	208	124	182	248	2	1	
270	385	27,600	39,500	DB	DF	222.5	138.5	182	248	2	1	
480	715	49,000	73,000	DB	DF	243	139	188	292	3	1.5	
435	650	44,000	66,500	DB	DF	306	202	188	292	3	1.5	
630	970	64,500	99,000	DB	DF	298	154	188	342	3	1.5	
575	890	59,000	90,500	DB	DF	366	222	188	342	3	1.5	
113	190	11,600	19,400	DB	DF	139	95	187	218	1	0.6	
213	325	21,700	33,500	DB	DF	190	124	190	240	2	1	
224	330	22,800	34,000	DB	—	217.5	151.5	192	247.5	2	1	
290	420	29,600	43,000	—	DF	160	94	192	247.5	2	1	
290	420	29,600	43,000	DB	DF	160	80	192	247.5	2	1	
251	380	25,600	38,500	—	DF	160	94	192	247.5	2	1	
355	530	36,500	54,000	DB	DF	225	133	192	268	2	1	
320	480	32,500	49,000	DB	DF	239	147	192	268	2	1	
495	770	50,500	78,500	DB	DF	248	144	198	302	3	1.5	
450	700	45,500	71,000	DB	DF	314	210	198	302	3	1.5	
665	1,070	68,000	109,000	DB	DF	311	161	198	362	3	1.5	
605	975	62,000	99,500	DB	DF	385	235	198	362	3	1.5	
138	232	14,100	23,700	DB	DF	148	100	198.5	231.5	1.5	1	
175	276	17,800	28,200	DB	—	215.5	157.5	202	243	2	1.5	
216	335	22,000	34,500	—	DF	163	97	200	249.5	2	1	
216	335	22,000	34,500	DB	DF	196	130	200	250	2	1	
215	335	21,900	34,500	DB	DF	166	83	202	257.5	2	1.5	
217	330	22,100	34,000	DB	—	226	160	202	257.5	2	2	
365	560	37,000	57,000	DB	DF	231	139	202	278	2	1	
325	505	33,000	51,500	DB	DF	247.5	155.5	202	278	2	1	
495	780	50,000	79,500	DB	DF	263	153	208	322	3	1.5	
445	705	45,000	72,000	DB	DF	333	223	208	322	3	1.5	
695	1,170	71,000	119,000	DB	DF	326	170	212	378	4	2	
635	1,070	64,500	109,000	DB	DF	404	248	212	378	4	2	
249	390	25,400	40,000	—	DF	169	99	207	258	2	1.5	

Angular Contact Ball Bearings (Single, Duplex)

NTN

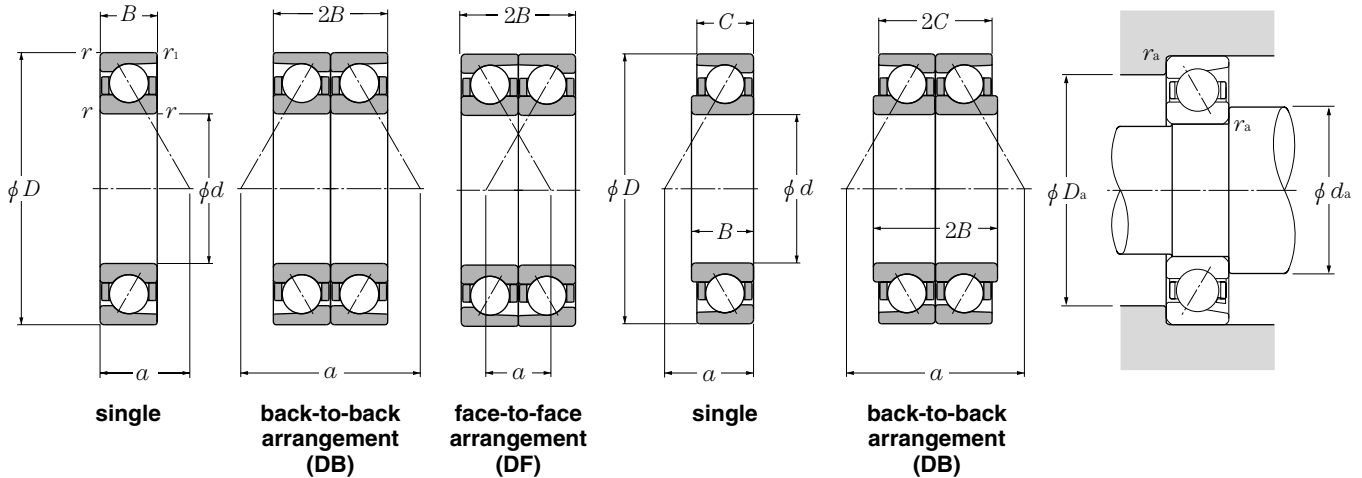

d 200~250mm

d	Boundary dimensions					contact angle α	dynamic C_r	Basic load ratings			Bearing numbers single	Drawing ^① No.	Load center a	Mass single (approx.) kg	
	mm							kN	static single						kgf
	D	B	C	$r_{s \min}$ ^②	$r_{is \min}$ ^②				C_{or}	C_r					
200	250	24	—	1.5	1	30	87.0	122	8,850	12,400	7840	A	77	2.68	
	279.5	38	—	2.5	1.5	40	165	202	16,800	20,600	SF4006	A	119.5	7.15	
	280	38	—	2.1	1.1	30	185	231	18,900	23,600	7940	A	88.5	7.15	
	289.5	38	—	2.5	1.5	40	188	238	19,200	24,200	SF4017	C	122	8.25	
	310	51	—	2.1	1.1	30	252	325	25,700	33,000	7040	A	99	14	
	310	51	—	2.1	1.1	40	226	293	23,000	29,900	7040B	A	132.5	14.1	
	360	58	—	4	1.5	30	335	450	34,500	46,000	7240	A	110	25.3	
	360	58	—	4	1.5	40	305	410	31,000	41,500	7240B	A	146	25.3	
	420	80	—	5	2	30	450	605	46,000	62,000	7340	A	130	53.1	
	420	80	—	5	2	40	410	555	42,000	56,500	7340B	A	170	53.1	
203.2	330.2	88.9	—	3	1.5	30	219	285	22,400	29,100	SF4104	A	99	14.7	
220	270	24	—	1.5	1	30	89.0	131	9,100	13,300	7844	A	82.5	2.91	
	300	38	—	2.1	1.1	30	187	239	19,000	24,300	7944	A	94	7.74	
	300	38	35	2.5	1.5	40	149	189	15,200	19,300	SF4407	F	126.5	7.25	
	309.5	38	—	2.1	1.1	40	190	246	19,400	25,100	SF4421	B	130	8.9	
	309.5	38	—	2.1	1.1	40	190	246	19,400	25,100	SF4433	C	130	8.9	
	319.5	46	—	2.1	1.1	35	226	299	23,000	30,500	SF4438	C	117.5	12.2	
	340	56	—	3	1.1	30	286	390	29,100	39,500	7044	A	109	18.2	
	340	56	—	3	1.1	40	238	325	24,300	33,000	7044B	A	145.5	18.4	
	400	65	—	4	1.5	30	345	485	35,000	49,500	7244	A	122	37.1	
	460	88	—	5	2	30	495	725	50,500	74,000	7344	A	142	72.4	
230	329.5	40	—	2.5	1.5	40	154	202	15,700	20,600	SF4614	E	135.5	11	
240	300	28	—	2	1	30	101	155	10,300	15,800	7848	A	92	4.49	
	320	38	—	2.1	1.1	30	193	255	19,600	26,000	7948	A	100	8.34	
	329.5	40	—	2.1	1.1	30	221	305	22,600	31,000	SF4839	C	102.5	10	
	329.5	40	—	2.5	1.5	40	197	265	20,100	27,000	SF4814	A	139.5	10.1	
	329.5	40	—	2.5	1.5	40	197	265	20,100	27,000	SF4818	B	139.5	10.1	
	340	40	—	2.5	1.5	30	211	289	21,500	29,400	SF4802	A	160.5	11.5	
	360	56	—	3	1.1	30	279	400	28,500	40,500	7048	A	114.5	19.5	
	360	56	—	3	1.1	40	249	355	25,400	36,000	7048B	A	154	19.8	
	440	72	—	4	1.5	30	420	630	42,500	64,500	7248	A	135.5	49.8	
	500	95	—	5	2	30	515	795	52,500	81,000	7348	A	154.5	92.2	
250	340	38	—	2.5	1	40	169	222	17,200	22,600	SF5005	F	141.5	9.55	
	349.5	46	—	3	1.5	30	233	325	23,700	33,000	SF5004	A	109.5	13.6	

① Drawing details are shown in Page B-15.

② Smallest allowable dimension for chamfer dimension r or r_1 .

Angular Contact Ball Bearings (Single, Duplex)

NTN

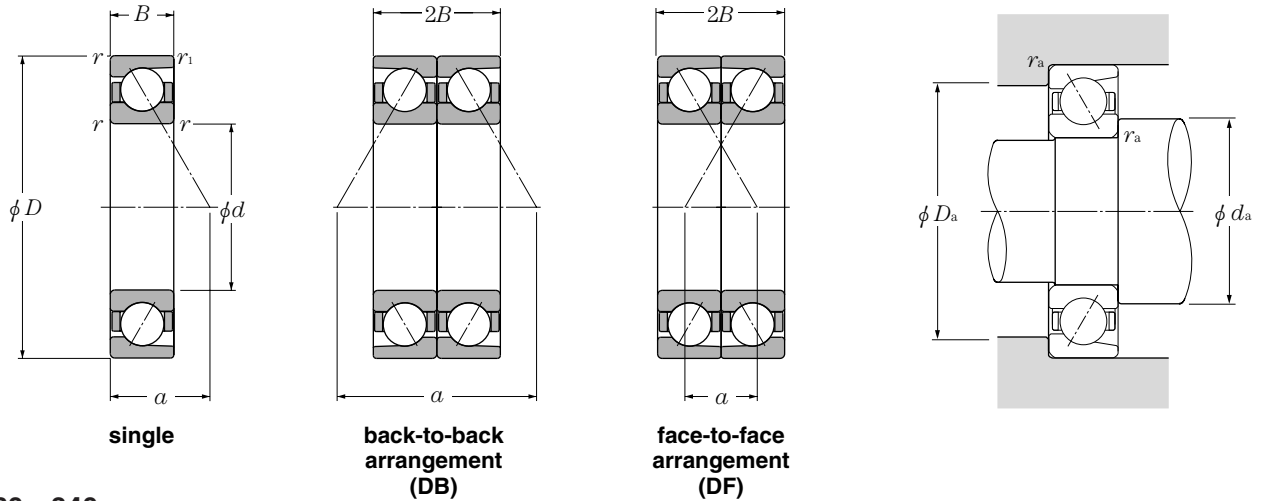

d 260~340mm

d	Boundary dimensions					contact angle α	dynamic C_r	Basic load ratings			Bearing numbers single	Drawing ^① No.	Load center mm a	Mass single kg (approx.)	
	mm							kN	static C_{or}	dynamic C_r					static C_{or}
	D	B	C	$r_{s\ min}^{\text{②}}$	$r_{is\ min}^{\text{②}}$										
260	320	28	—	2	1	30	127	192	12,900	19,600	7852	A	97.5	4.83	
	360	46	—	2.1	1.1	30	258	375	26,300	38,000	7952	A	112	14	
	369.5	46	—	2.5	1.5	40	235	340	23,900	34,500	SF5206	C	155	16.1	
	369.5	46	—	2.5	1.5	40	235	340	23,900	34,500	SF5225	B	155	15.7	
	369.5	46	—	2.5	1.5	40	235	340	23,900	34,500	SF5224	A	155	15.7	
	369.5	46	—	2.5	1.5	30	242	350	24,700	35,500	SF5210	D	114	15.7	
	379.5	56	—	4	2	40	264	385	26,900	39,500	SF5218	A	162.5	19.1	
	400	65	—	4	1.5	30	315	455	32,000	46,500	7052	A	128	28.7	
	400	65	—	4	1.5	40	282	410	28,700	41,500	7052B	A	171	29	
	480	80	—	5	2	30	480	750	48,500	76,500	7252	A	147	66	
540	102	—	6	3	30	590	960	60,000	98,000	7352	A	166.5	115		
280	350	33	—	2	1	30	164	247	16,700	25,200	7856	A	107.5	7.17	
	380	46	—	2.1	1.1	30	261	385	26,600	39,500	7956	A	118	14.8	
	389.5	46	—	2.1	1.1	40	223	325	22,700	33,000	SF5606	A	163.5	16	
	389.5	46	—	2.5	1.5	30	250	370	25,500	38,000	SF5608	D	119.5	16	
	420	65	—	4	1.5	30	390	595	40,000	60,500	7056	A	133.5	30.7	
	420	65	—	4	1.5	40	350	540	35,500	55,000	7056B	A	179.5	30.9	
	500	80	—	5	2	30	535	860	54,500	87,500	7256	A	152.5	69.7	
	580	108	—	6	3	30	670	1,140	68,000	116,000	7356	A	178	140	
285	380	46	—	2.5	2	40	206	305	21,000	31,000	SF5702	A	162.5	14.7	
290	419.5	60	—	5	2.5	40	292	455	29,800	46,500	SF5803	B	179	26.9	
300	380	38	—	2.1	1.1	30	193	290	19,700	29,500	7860	A	117	10.1	
	420	56	—	3	1.1	30	325	520	33,500	53,000	7960	A	132	23.7	
	460	74	—	4	1.5	30	440	715	45,000	73,000	7060	A	146.5	43.4	
	460	74	—	4	1.5	40	395	645	40,500	66,000	7060B	A	196.5	43.7	
	540	85	—	5	2	30	550	930	56,500	94,500	7260	A	164	87.2	
310	429.5	60	—	4	2	40	297	470	30,500	48,000	SF6203	A	185.5	26.7	
320	400	38	—	2.1	1.1	30	197	305	20,100	31,000	7864	A	123	10.7	
	440	56	—	3	1.1	30	330	540	34,000	55,000	7964	A	137.5	24.7	
	480	74	—	4	1.5	30	450	760	46,000	77,500	7064	A	152.5	45.7	
	580	92	—	5	2	30	635	1,120	64,500	114,000	7264	A	176	109	
340	420	38	—	2.1	1.1	30	204	325	20,800	33,500	7868	A	128.5	11.3	

① Drawing details are shown in Page B-15.

② Smallest allowable dimension for chamfer dimension r or r_1 .

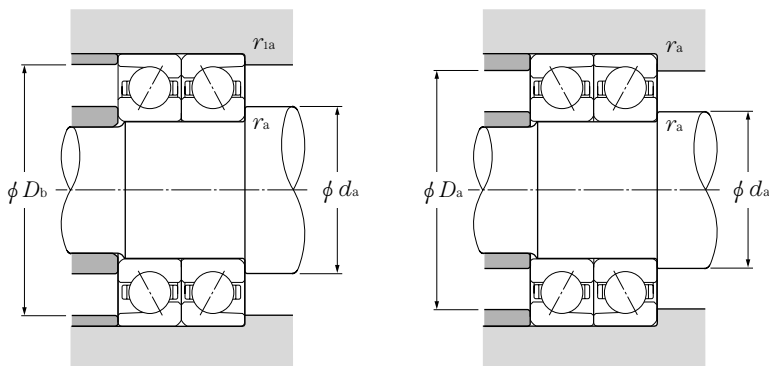

Equivalent bearing load

dynamic

$$P_r = X F_r + Y F_a$$

Contact angle	e	Single				DB, DF			
		$F_a/F_r \leq e$		$F_a/F_r > e$		$F_a/F_r \leq e$		$F_a/F_r > e$	
		X	Y	X	Y	X	Y	X	Y
30°	0.80	1	0	0.39	0.76	1	0.78	0.63	1.24
40°	1.14	1	0	0.35	0.57	1	0.55	0.57	0.93

static

$$P_{or} = X_o F_r + Y_o F_a$$

Contact angle	Single		DB, DF	
	X_o	Y_o	X_o	Y_o
30°	0.5	0.33	1	0.66
40°	0.5	0.26	1	0.52

For single, When $P_{or} < F_r$ use $P_{or} = F_r$

dynamic	Basic load ratings		static	Bearing numbers		Load center		Abutment and fillet dimensions								
	static	dynamic (duplex)		static	static	static	mm	mm	mm	mm	mm	mm				
C_r	KN	C_r	kgf	C_{or}	C_r	C_{or}	C_r	C_{or}	DB	DF	DB	DF	d_a min	D_a max	r_{as} max	r_{ias} max
206	385	21,000	39,000	DB	DF	195.5	139.5	270	310	2	1					
420	750	42,500	76,500	DB	DF	270	178	272	348	2	1					
380	680	39,000	69,000	—	DF	310.5	218.5	272	357.5	2	1.5					
380	680	39,000	69,000	DB	—	310.5	218.5	272	357.5	2	1.5					
380	680	39,000	69,000	DB	DF	310.5	218.5	272	357.5	2	1.5					
395	695	40,000	71,000	DB	DF	228	136	272	357.5	2	1.5					
430	775	44,000	79,000	DB	DF	324.5	212.5	278	361.5	3	2					
510	905	52,000	92,500	DB	DF	255.5	125.5	278	382	3	1.5					
458	820	46,500	83,500	DB	DF	342	212	278	382	3	1.5					
775	1,500	79,000	153,000	DB	DF	294	134	282	458	4	2					
960	1,920	98,000	196,000	DB	DF	333	129	288	512	5	2.5					
267	495	27,200	50,500	DB	DF	215	148	290	340	2	1					
425	775	43,000	79,000	DB	DF	282	190	292	368	2	1					
360	650	37,000	66,500	DB	DF	327	235	292	377.5	2	1					
405	745	41,500	76,000	DB	DF	239.5	147.5	292	377.5	2	1.5					
635	1,190	64,500	121,000	DB	DF	267	137	298	402	3	1.5					
570	1,080	58,000	110,000	DB	DF	359	229	298	402	3	1.5					
870	1,720	88,500	175,000	DB	DF	305	145	258	478	4	2					
1,080	2,270	111,000	232,000	DB	DF	356.5	140.5	308	552	5	2.5					
335	605	34,000	62,000	DB	DF	325	233	297	368	2	2					
475	910	48,500	93,000	DB	—	357.5	237.5	312	397.5	4	2					
315	580	32,000	59,000	DB	DF	234.5	158.5	312	368	2	1					
530	1,040	54,000	106,000	DB	DF	320	208	314	406	2.5	1					
715	1,430	73,000	146,000	DB	DF	293.5	145.5	318	442	3	1.5					
640	1,290	65,500	132,000	DB	DF	393	245	318	442	3	1.5					
895	1,860	91,500	189,000	DB	DF	327.5	157.5	322	518	4	2					
480	945	49,000	96,000	DB	—	370.5	250.5	328	411.5	3	2					
320	610	32,500	62,000	DB	DF	246	170	332	388	2	1					
540	1,080	55,000	110,000	DB	DF	275.5	163.5	334	426	2.5	1					
735	1,520	75,000	155,000	DB	DF	305	152.5	338	462	3	1.5					
1,030	2,230	105,000	228,000	DB	DF	352	168	342	558	4	2					
330	650	34,000	66,500	DB	DF	257.5	181.5	352	408	2	1					

Angular Contact Ball Bearings (Single, Duplex)

NTN

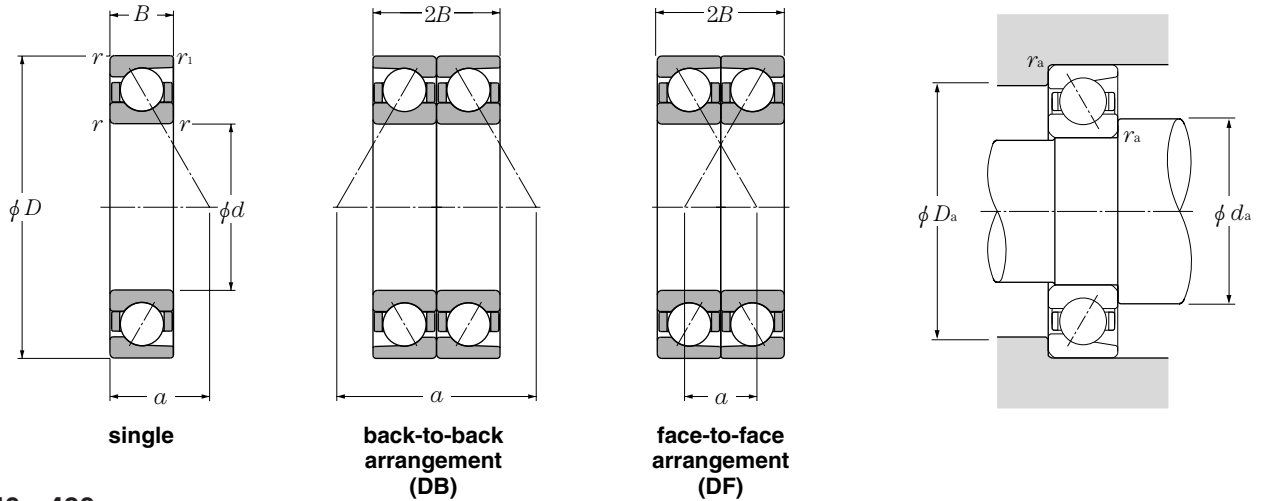

d 340~480mm

d	Boundary dimensions					contact angle α	dynamic C_r	Basic load ratings			Bearing numbers single	Drawing ^① No.	Load center mm a	Mass single kg (approx.)	
	mm							kN	static C_{or}	dynamic C_r					static C_{or}
	D	B	C	$r_{s\ min}^{\text{②}}$	$r_{is\ min}^{\text{②}}$										
340	460	56	—	3	1.1	30	345	575	35,000	59,000	7968	A	143.5	26.0	
	479.5	65	—	4	2	30	395	680	40,500	69,500	SF6807	A	151	36.7	
	520	82	—	5	2	30	520	905	53,000	92,500	7068	A	165	61.1	
	620	92	—	5	2	30	650	1,200	66,500	122,000	7268	A	184.5	127	
360	440	38	—	2.1	1.1	30	226	365	23,100	37,000	7872	A	134.5	11.9	
	480	56	—	3	1.1	30	350	595	35,500	60,500	7972	A	149.5	27.3	
	509.5	70	—	5	2	40	390	685	40,000	69,500	SF7203	A	217.5	45	
	540	82	—	5	2	30	530	960	54,500	98,000	7072	A	171	63.4	
	650	95	—	6	3	30	670	1,280	68,500	130,000	7272	A	193.5	143	
380	480	46	—	2.1	1.1	30	281	475	28,700	48,500	7876	A	147	19.5	
	519.5	65	—	4	2	40	345	610	35,500	62,500	SF7603	A	221.5	41.3	
	520	65	—	4	1.5	30	390	700	40,000	71,000	7976	A	162.5	39.6	
	540	164	—	4	2	40	440	810	45,000	83,000	SF7601	A	234	61	
	560	82	—	5	2	30	545	1,010	55,500	103,000	7076	A	176.5	66.3	
400	500	46	—	2.1	1.1	30	287	500	29,300	51,000	7880	A	153	20.4	
	540	65	—	4	1.5	30	395	720	40,000	73,500	7980	A	168	41	
	600	90	—	5	2	30	615	1,180	63,000	121,000	7080	A	189.5	86.1	
420	520	46	—	2.1	1.1	30	310	555	31,500	56,500	7884	A	158.5	21.1	
	560	65	—	4	1.5	30	410	765	41,500	78,000	7984	A	174	42.8	
	620	90	—	5	2	30	630	1,250	64,500	127,000	7084	A	195	89.7	
440	540	46	—	2.1	1.1	30	310	565	31,500	58,000	7888	A	164.5	22	
	600	74	—	4	1.5	30	445	860	45,500	87,500	7988	A	187	59.3	
	650	94	—	6	3	30	645	1,310	65,500	134,000	7088	A	204.5	103	
460	540	40	—	2.1	1.1	30	249	455	25,400	46,000	SF9211	A	164.5	15.8	
	580	56	—	3	1.1	30	380	725	39,000	74,000	7892	A	178	33.5	
	620	74	—	4	1.5	30	450	885	46,000	90,000	7992	A	193	61.6	
	680	100	—	6	3	30	720	1,510	73,500	154,000	7092	A	214.5	119	
470	570	50	—	2.1	1.1	30	320	605	32,500	62,000	SF9404	A	175	25.7	
480	600	56	—	3	1.1	30	390	760	40,000	77,500	7896	A	184	34.9	
	650	78	—	5	2	30	530	1,090	54,000	111,000	7996	A	202	71.8	
	700	100	—	6	3	30	715	1,520	73,000	155,000	7096	A	220.5	123	

① Drawing details are shown in Page B-15.

② Smallest allowable dimension for chamfer dimension r or r₁.

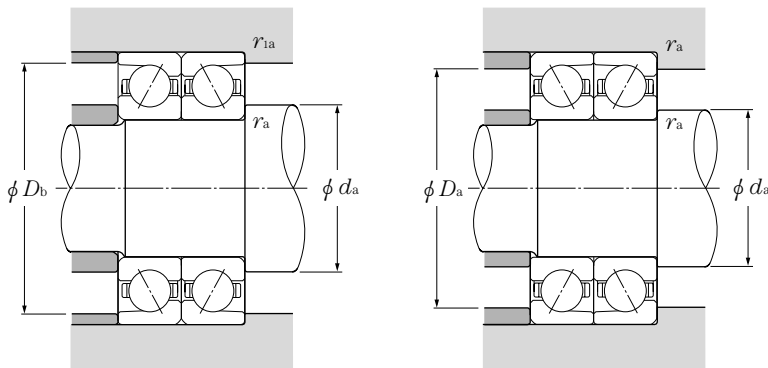

Equivalent bearing load

dynamic

$$P_r = X F_r + Y F_a$$

Contact angle	e	Single				DB, DF			
		$F_a/F_r \leq e$		$F_a/F_r > e$		$F_a/F_r \leq e$		$F_a/F_r > e$	
		X	Y	X	Y	X	Y	X	Y
30°	0.80	1	0	0.39	0.76	1	0.78	0.63	1.24
40°	1.14	1	0	0.35	0.57	1	0.55	0.57	0.93

static

$$P_{or} = X_o F_r + Y_o F_a$$

Contact angle	Single		DB, DF	
	X_o	Y_o	X_o	Y_o
30°	0.5	0.33	1	0.66
40°	0.5	0.26	1	0.52

For single, When $P_{or} < F_r$ use $P_{or} = F_r$

dynamic	Basic load ratings		static	Bearing numbers		Load center		Abutment and fillet dimensions			
	static	dynamic (duplex)		static	static	mm	mm	mm	mm	mm	mm
C_r	KN	C_r	kgf	DB	DF	DB	DF	d_a min	D_a max	r_{as} max	r_{ias} max
560	1,150	57,000	118,000	DB	DF	287	175	354	446	2.5	1
645	1,360	65,500	139,000	—	DF	301.5	171.5	358	461.5	3	2
845	1,810	86,000	185,000	DB	DF	330.5	166.5	362	498	4	2
1,060	2,400	108,000	244,000	DB	DF	369	185	362	598	4	2
370	725	37,500	74,000	DB	DF	269	193	372	428	2	1
565	1,190	57,500	121,000	DB	DF	298.5	186.5	374	466	2.5	1
635	1,370	64,500	140,000	DB	—	435	295	382	487.5	4	2
865	1,920	88,000	196,000	DB	DF	342	178	382	518	4	2
1,090	2,550	111,000	260,000	DB	DF	386.5	196.5	388	622	5	2.5
455	955	46,500	97,500	DB	DF	294.5	202.5	392	468	2	1
565	1,220	57,500	125,000	DB	—	442.5	312.5	398	501.5	3	2
635	1,400	64,500	142,000	DB	DF	325	195	398	502	3	1.5
715	1,620	73,000	166,000	—	DF	468	304	398	522	3	2
865	1,920	88,000	196,000	DB	DF	342	178	402	538	4	2
465	1,000	47,500	102,000	DB	DF	306	214	412	488	2	1
640	1,440	65,500	147,000	DB	DF	336.5	206.5	418	522	3	1.5
1,000	2,370	102,000	241,000	DB	DF	379	199	422	578	4	2
505	1,110	51,500	113,000	DB	DF	317.5	225.5	432	508	2	1
660	1,530	67,500	156,000	DB	DF	348	218	438	542	3	1.5
1,030	2,500	105,000	255,000	DB	DF	390.5	210.5	442	598	4	2
505	1,130	51,500	116,000	DB	DF	329	237	452	528	2	1
720	1,720	73,500	175,000	DB	DF	374.5	226.5	458	582	3	1.5
1,050	2,630	107,000	268,000	DB	DF	409	221	468	622	5	2.5
405	905	41,500	92,500	DB	—	328.5	248.5	472	528	2	1
620	1,450	63,000	148,000	DB	DF	356.5	244.5	474	566	2.5	1
730	1,770	74,500	180,000	DB	DF	386	238	478	602	3	1.5
117	300	12,000	31,000	DB	DF	429	229	488	652	5	2.5
520	1,210	53,000	124,000	DB	—	350	250	482	558	2	1
635	1,520	64,500	155,000	DB	DF	368	256	494	586	2.5	1
860	2,180	88,000	223,000	DB	DF	404.5	248.5	502	628	4	2
1,170	3,050	119,000	310,000	DB	DF	441	241	508	672	5	2.5

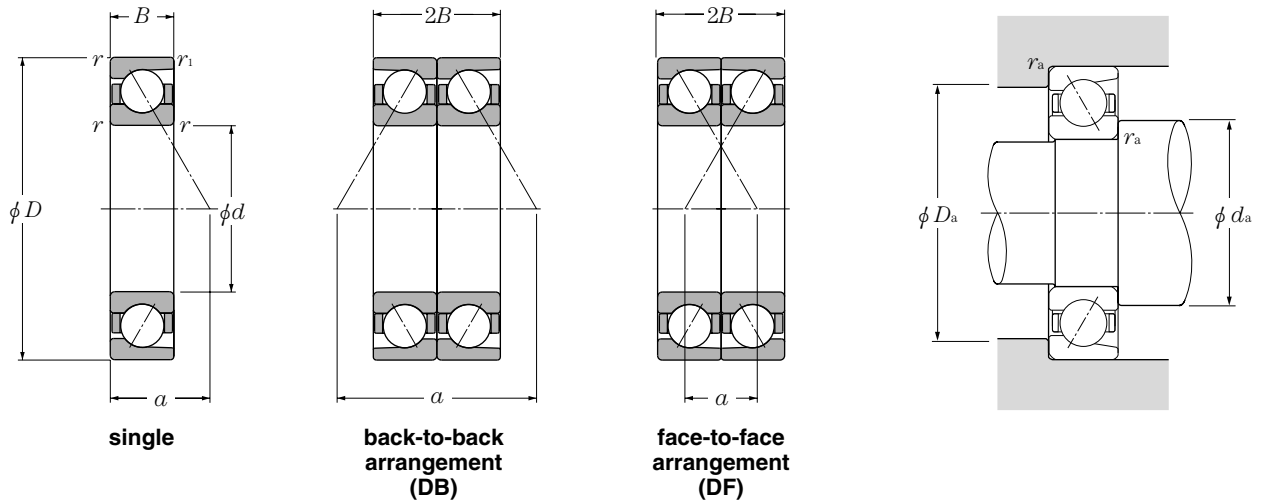

d 500~1,060mm

d	Boundary dimensions					contact angle α	dynamic C_r	Basic load ratings			Bearing numbers single	Drawing ^① No. A	Load center mm a	Mass single kg (approx.)	
	mm							kN	static C_{or}	dynamic C_r					static C_{or}
	D	B	C	$r_{s\ min}^{\text{②}}$	$r_{ls\ min}^{\text{②}}$										
500	620	56	—	3	1.1	30	395	780	40,000	79,500	78/500	A	189.5	36.5	
	670	78	—	5	2	30	540	1,120	55,000	115,000	79/500	A	208	74.9	
	720	100	—	6	3	30	735	1,590	75,000	163,000	70/500	A	226	129	
560	700	100	—	5	2.5	30	670	1,450	68,000	147,000	SF10013	A	223	87.3	
	750	85	—	5	2	30	620	1,380	63,500	141,000	79/560	A	231.5	105	
630	780	69	—	4	1.5	30	500	1,140	51,000	116,000	78/630A	A	238	72.2	
670	820	69	—	4	1.5	30	475	1,080	48,000	110,000	78/670	A	249.5	76.3	
	820	69	—	4	1.5	40	420	945	43,000	96,500	78/670B	A	347	76.3	
700	900	74	—	4	1.5	30	530	1,290	54,000	131,000	SF14001	A	268	117	
1,000	1,420	130	—	7.5	4	30	1,440	4,650	147,000	470,000	SF20001	A	414.5	654	
1,060	1,280	100	—	6	3	30	880	2,680	895,000	273,000	78/1060	A	387.5	255	

① Drawing details are shown in Page B-15.
 ② Smallest allowable dimension for chamfer dimension r or r_1 .

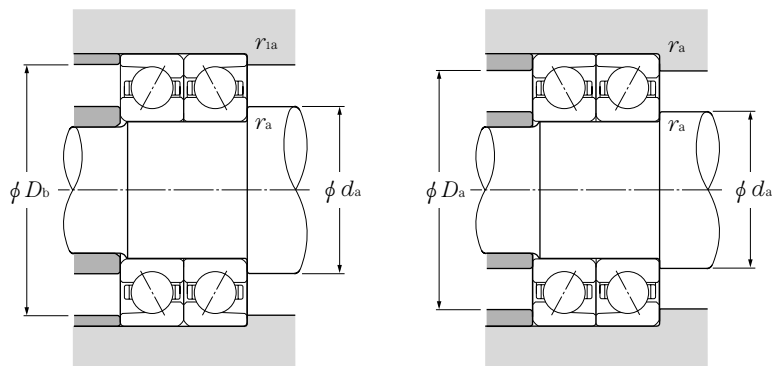

Equivalent bearing load

dynamic

$$P_r = X F_r + Y F_a$$

Contact angle	e	Single				DB, DF			
		$F_a/F_r \leq e$		$F_a/F_r > e$		$F_a/F_r \leq e$		$F_a/F_r > e$	
		X	Y	X	Y	X	Y	X	Y
30°	0.80	1	0	0.39	0.76	1	0.78	0.63	1.24
40°	1.14	1	0	0.35	0.57	1	0.55	0.57	0.93

static

$$P_{or} = X_o F_r + Y_o F_a$$

Contact angle	Single		DB, DF	
	X_o	Y_o	X_o	Y_o
30°	0.5	0.33	1	0.66
40°	0.5	0.26	1	0.52

For single, When $P_{or} < F_r$ use $P_{or} = F_r$

dynamic	Basic load ratings				Bearing numbers (duplex)		Load center mm		Abutment and fillet dimensions mm			
	static	dynamic (duplex)	static	dynamic					d_a min	D_a max	r_{as} max	r_{1as} max
C_r	C_{or}	C_r	C_{or}	DB	DF	DB	DF	a				
640	1,560	65,000	159,000	DB	DF	379.5	267.5	514	606	2.5	1	
875	2,250	89,000	229,000	DB	DF	416	260	522	648	4	2	
1,190	3,200	122,000	325,000	DB	DF	452.5	252.5	528	692	5	2.5	
1,080	2,890	111,000	295,000	DB	DF	446.5	246.5	522	678	4	2	
1,010	2,760	103,000	281,000	DB	DF	463.5	293.5	582	728	4	2	
815	2,270	83,000	232,000	DB	DF	476	338	648	762	3	1.5	
770	2,150	78,500	219,000	DB	DF	499	361	688	802	3	1.5	
680	1,890	69,500	193,000	DB	DF	694	556	688	802	3	1.5	
860	2,580	88,000	263,000	DB	DF	536	388	718	882	3	1.5	
2,340	9,250	238,000	945,000	DB	DF	828.5	568.5	1,036	1,384	6	3	
1,430	5,350	146,000	545,000	DB	DF	775.5	575.5	1,088	1,252	5	2.5	



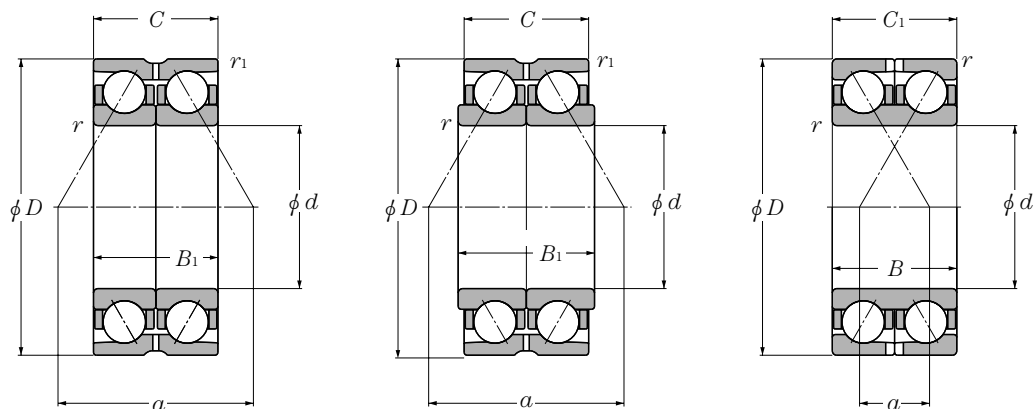

d 100~190mm

d	Boundary dimensions					Contact angle α	dynamic C_r	Basic load ratings		static C_{or}	Bearing numbers	Drawing No.
	D	B or B_1	C or C_1	$r_{s \min}$ ^①	$r_{ls \min}$ ^②			static C_{or}	dynamic C_r			
100	170	60.3	60.3	2.5	2.5	40	160	179	16,300	18,200	DE2010	D
110	169.5	56	56	2.5	—	30	149	186	15,200	18,900	DE2208	B
120	190	66	66	2.5	1	30	187	236	19,000	24,100	DE2405	F
	190	66	66	2.5	1	30	187	236	19,000	24,100	DE2409	D
130	200	66	66	2.5	—	30	191	251	19,400	25,600	DE2601	B
140	210	66	66	2	—	40	203	266	20,700	27,100	DE2812	A
	210	66	66	1	—	40	179	248	18,300	25,300	DE2806	B
	210	66	66	2.5	—	30	194	265	19,800	27,000	DE2807	B
150	225	70	70	2.5	—	30	222	305	22,700	31,500	DE3010	A
	225	70	70	2.5	—	30	222	305	22,700	31,500	DE3011	B
	225	73	73	2.5	—	30	216	293	22,000	29,900	DE3009	A
	230	70	70	2.5	1.5	30	222	305	22,700	31,500	DE3007	F
	230	70	70	2	2	40	198	275	20,200	28,100	DE3019	D
160	215	56	50	2	1.1	40	123	186	12,500	18,900	DE3207	C
	240	76	76	2.5	—	30	252	355	25,700	36,000	DE3201	A
170	260	84	84	2.5	—	30	300	430	31,000	43,500	DE3402	A
175	280	92	92	2.5	—	40	320	480	32,500	49,000	DE3502	A
	280	92	92	2.5	—	40	320	480	32,500	49,000	DE3501	A
180	250	66	66	2.5	—	40	185	275	18,900	28,000	DE3606	A
	250	70	70	2.5	1	40	190	285	19,300	29,100	DE3609	F
	259.5	66	66	2.5	1	30	212	325	21,600	33,000	DE3610	D
	259.5	66	66	2.5	1	30	212	325	21,600	33,000	DE3601	F
	259.5	66	66	2.5	—	40	224	330	22,800	34,000	DE3608	B
	259.5	66	66	2	—	40	224	330	22,800	34,000	DE3615	A
	259.5	66	66	2.5	—	30	251	380	25,600	38,500	DE3603	A
	259.5	66	66	2.5	2.5	30	212	325	21,600	33,000	DE3612	D
	280	92	92	2.5	—	30	345	505	35,000	51,500	DE3605	A
190	269.5	66	66	2.5	1	30	215	335	21,900	34,500	DE3807	D
	269.5	66	66	2.5	1	30	215	335	21,900	34,500	DE3801	F

① Drawing details are shown in Page B-16.

② Smallest allowable dimension for chamfer dimension r or r_1 .

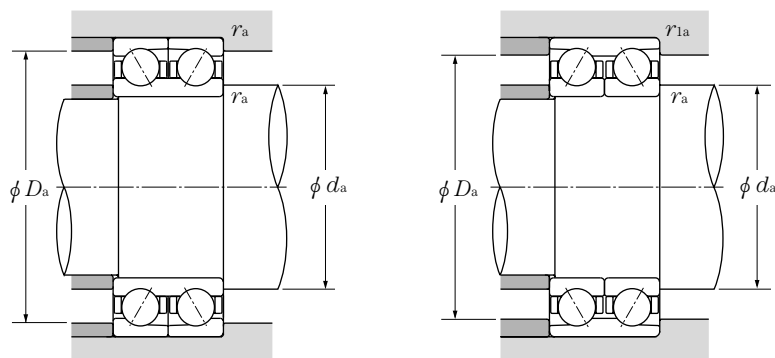

Equivalent bearing load

dynamic

$$P_r = X F_r + Y F_a$$

Contact angle	e	Single				DB, DF			
		$F_a/F_r \leq e$		$F_a/F_r > e$		$F_a/F_r \leq e$		$F_a/F_r > e$	
		X	Y	X	Y	X	Y	X	Y
30°	0.80	1	0	0.39	0.76	1	0.78	0.63	1.24
40°	1.14	1	0	0.35	0.57	1	0.55	0.57	0.93

static

$$P_{or} = X_o F_r + Y_o F_a$$

Contact angle	Single		DB, DF	
	X _o	Y _o	X _o	Y _o
30°	0.5	0.33	1	0.66
40°	0.5	0.26	1	0.52

For single, When $P_{or} < F_r$ use $P_{or} = F_r$

Abutment and fillet dimensions mm				Load center mm	Mass kg
d_a min	D_a max	r_{as} max	r_{las} max	a	(approx.)
158	112	2	2	143	5.64
157.5	112	2	—	54.5	4.61
184.5	132	2	1	122	7.09
184.5	132	2	1	122	7.09
188	142	2	—	64	7.54
198	150	2	—	90	8
204.5	152	2	—	90	7.76
198	152	2	—	67	7.72
213	162	2	—	71.5	9.74
213	162	2	—	71.5	9.74
213	162	2	—	72.5	9.69
221.5	162	2	1.5	143	9.74
221.5	158.5	2	2	194	9.74
208	170	2	1	182	5.71
228	172	2	—	76.5	12
248	182	2	—	111	16.1
268	187	2	—	119	21.7
268	187	2	—	88.5	21.7
238	192	2	—	106	9.83
244.5	192	2	1	215	10.4
254	192	2	1	160	10.4
254	192	2	1	160	10.4
247.5	192	2	—	109	10.7
249.5	190	2	—	109	10.7
247.5	192	2	—	80	10.7
247.5	192	2	2	160	10.4
268	192	2	—	89.5	20.9
264	202	2	1	166	11.9
264	202	2	1	166	11.9



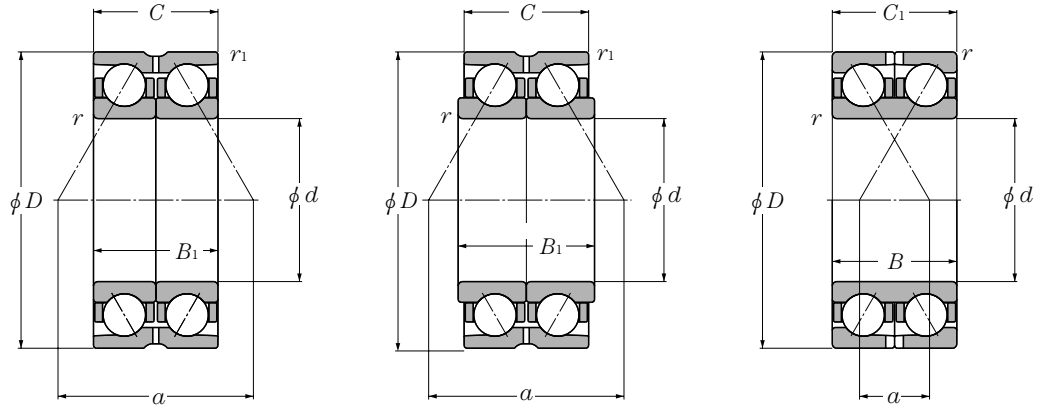

d 200~360mm

d	Boundary dimensions					Contact angle α	Basic load ratings		Bearing numbers	Drawing No.		
	D	B or B ₁	CorC ₁	r _{s min} ^①	r _{ls min} ^②		dynamic kN	static kgf				
200	279.5	76	76	2.5	1.5	30	253	405	25,800	41,500	DE4004	F
	279.5	76	76	2.5	—	30	253	405	25,800	41,500	DE4008	B
	289.5	76	76	2.5	1.5	40	260	385	26,500	39,500	DE4010	G
	289.5	76	76	2.5	2.1	30	269	420	27,500	42,500	DE4019	D
	289.5	76	76	2.5	1.5	30	269	420	27,500	42,500	DE4009	F
	289.5	76	76	2.5	1.5	30	269	420	27,500	42,500	DE4002	F
	289.5	76	76	2.5	1.5	30	269	420	27,500	42,500	DE4012	D
	310	102	102	2.5	—	30	410	650	41,500	66,000	DE4007	A
220	309.5	76	76	2.5	—	30	325	520	33,000	53,000	DE4403	A
	309.5	76	76	2.5	—	30	325	520	33,000	53,000	DE4404	A
	309.5	76	76	2.1	1.1	30	325	520	33,000	53,000	DE4408	D
	319.5	92	92	2.5	—	30	375	625	38,500	63,500	DE4409	A
	319.5	92	92	2.5	—	40	335	550	34,500	56,000	DE4406	A
230	329.5	80	80	2.5	1.5	30	350	585	36,000	59,500	DE4602	F
	329.5	80	80	2.5	1.5	30	350	585	36,000	59,500	DE4603	D
	329.5	80	80	2.5	1.5	30	350	585	36,000	59,500	DE4605	E
240	359.5	112	112	3	1.5	40	440	770	45,000	78,500	DE4803	F
250	340	76	70	2	2	30	272	480	27,800	49,000	DE5004	C
260	369.5	92	92	2.5	—	40	380	680	39,000	69,000	DE5213	A
	369.5	92	92	2.5	—	30	430	775	43,500	79,000	DE5211	A
	369.5	92	92	2.5	2.5	30	395	695	40,000	71,000	DE5212	F
280	389.5	92	92	2.1	1.1	30	405	745	41,500	76,000	DE5605	D
300	429.5	112	112	3	—	30	530	1,040	54,000	106,000	DE6001	A
360	540	164	164	5	—	30	725	1,630	74,000	166,000	DE7201	A

① Drawing details are shown in Page B-16.

② Smallest allowable dimension for chamfer dimension r or r₁.

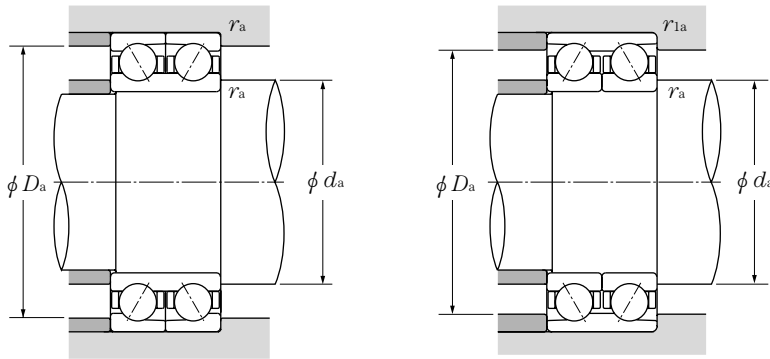

Equivalent bearing load

dynamic

$$P_r = XF_r + YF_a$$

Contact angle	e	Single				DB, DF			
		$F_a/F_r \leq e$		$F_a/F_r > e$		$F_a/F_r \leq e$		$F_a/F_r > e$	
		X	Y	X	Y	X	Y	X	Y
30°	0.80	1	0	0.39	0.76	1	0.78	0.63	1.24
40°	1.14	1	0	0.35	0.57	1	0.55	0.57	0.93

static

$$P_{0r} = X_0 F_r + Y_0 F_a$$

Contact angle	Single		DB, DF	
	X_0	Y_0	X_0	Y_0
30°	0.5	0.33	1	0.66
40°	0.5	0.26	1	0.52

For single, When $P_{0r} < F_r$ use $P_{0r} = F_r$

Abutment and fillet dimensions mm				Load center mm	Mass kg
d_a min	D_a max	r_{as} max	r_{las} max	a	(approx.)
271	212	2	1.5	177	14.3
267.5	212	2	—	88.5	14.3
281	212	2	1.5	244	16.5
277.5	212	2	2	179	16.4
281	212	2	1.5	180	16.4
281	212	2	1.5	179	16.4
281	212	2	1.5	179	16.4
298	212	2	—	99	28.3
<hr/>					
297.5	232	2	—	95.5	17.8
297.5	232	2	—	95.5	17.8
302.5	232	2	1	191	17.8
307.5	232	2	—	101	24.4
307.5	232	2	—	136	24.4
<hr/>					
321	242	2	1.5	202	22
321	242	2	1.5	202	22
321	242	2	1.5	202	22
<hr/>					
351	254	2.5	1.5	308	39.7
<hr/>					
328	262	2	2	208	18.4
<hr/>					
357.5	272	2	—	155	31.3
357.5	272	2	—	114	31.3
357.5	272	2	2	228	30.9
<hr/>					
382.5	292	2	1	239	33.4
<hr/>					
417.5	312	2.5	—	132	52.4
<hr/>					
518	382	4	—	171	131

